

ISOMETER[®] iso175

Insulation monitoring device for unearthed drive systems (IT systems) in road vehicles

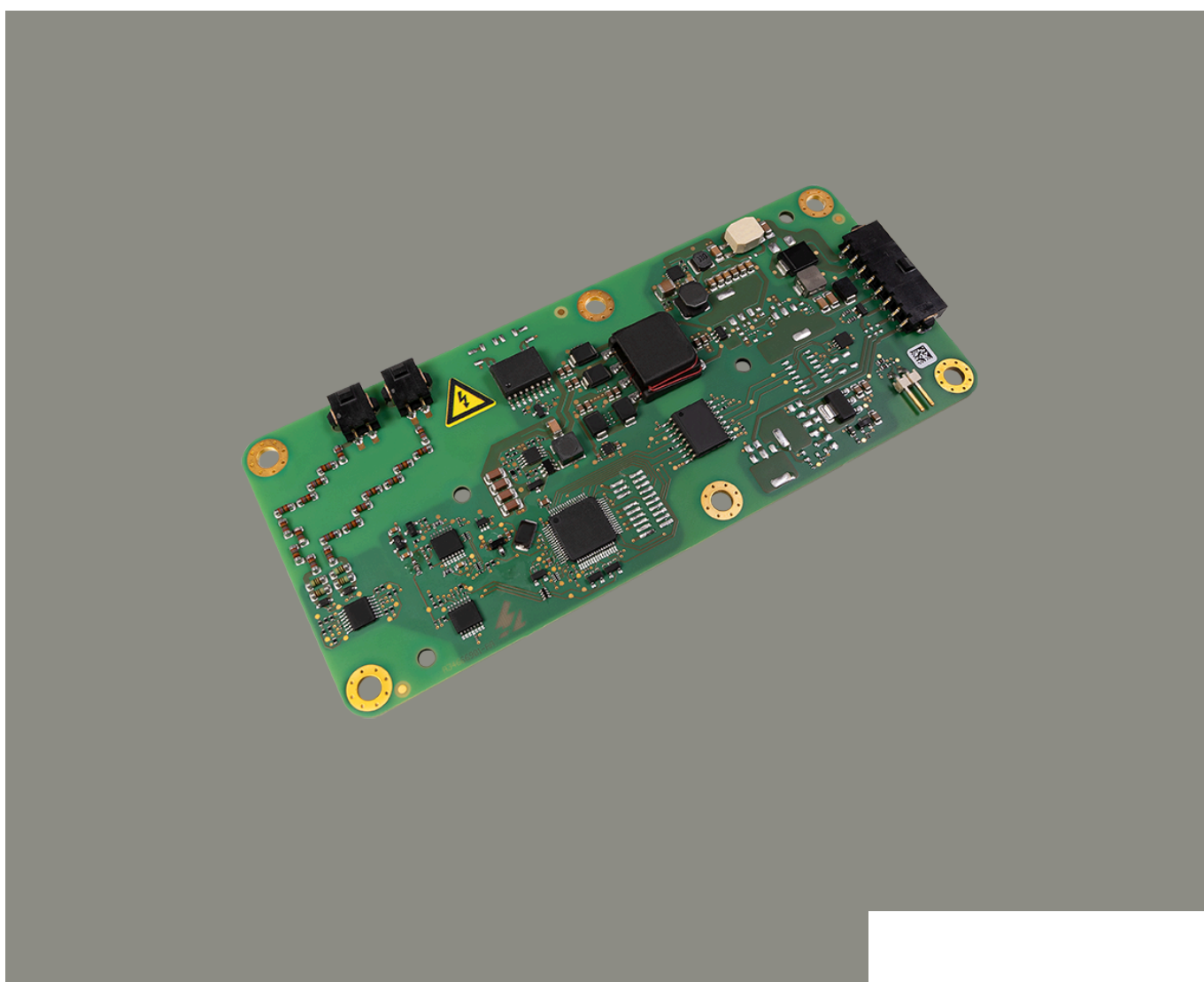

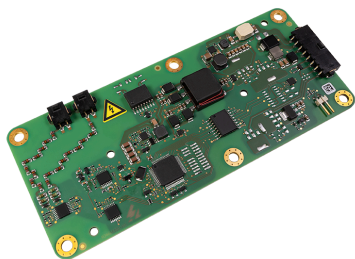

Device features

- Suitable for 12 V and 24 V DC systems (supply voltage)
- Insulation monitoring of DC insulation faults for unearthed systems (IT systems) DC 0...1000 V
- Continuous insulation resistance measurement $R_{F_corrected} = 0...35 \text{ M}\Omega$ ($R_{F_original} = 0...50 \text{ M}\Omega$)
- Response time $\leq 30 \text{ s}$ for insulation resistances $\leq 500 \text{ }\Omega/\text{Volt}$ and system leakage capacitances $\leq 2 \mu\text{F}$
- Insulation measurement for system leakage capacitances up to $10 \mu\text{F}$ can be configured by setting parameters in the high capacitance ("High Capacity") profile.
- Insulation measurement also when the vehicle's HV electric system is not energised
- Integrated self diagnosis (online self test)
- HV connection monitoring (offline self test)
- Continuous monitoring of the earth connection
- Undervoltage detection
- Earth connection can be disconnected
- Interfaces:
 - Digital output for device error message (OK_{HS})
 - HS-CAN interface with the following protocols
 - Bender CAN
 - CAN-SAE J1939
 - All outputs short-circuit proof
- Load-dump protection up to 58 V

Intended use

The ISOMETER® iso175 product line, called ISOMETER® in the following, is designed for installation in correspondingly marked HV-components of road vehicles. There it continuously monitors the insulation resistance of the HV system. Depending on the variant, the device communicates with a higher-level location using different CAN protocols (standard Bender, SAEJ1939).

- i** Other installation locations in the vehicle or in industry sectors such as e. g. the shipping, railroad or aerospace industries are considered non-compliant with the intended use.

Function

Insulation resistance measurement

The overall insulation resistance measurement of an HV system is based on the patented active AMP measuring principle. This method uses a measuring voltage source internal to the device that injects a current into the system to be measured, and the resulting voltage drop is measured. This is carried out independently of the voltage of the system to be monitored so that the insulation measurement can also be carried out when the HV system is deenergised.



ADVICE

For a correct insulation resistance measurement, a low-resistance connection between HV+ and HV- is required.

The measuring duration for an individual measurement generally depends on the following factors and it can take up to 60 seconds:

- Overall insulation resistance of the HV system
- System leakage capacitance
- Measuring profile used (device parameter)

The present duration of an individual insulation measurement is output by the measured value Isolation: *Time_elapsed_since_last_measurement*. At the beginning of each new insulation measurement this value is automatically reset to 0 s.

Due to the then following internal statistical filtering and averaging of the individual measured values, the insulation resistance measured value is only available at the device interface with a delay (after up to 12 individual measurements).

When the fast start measurement is activated (Power-On profile "Standard with fast startup" or "High Capacity with fast startup"), the insulation resistance measured values ($R_{iso_original}$, $R_{iso_corrected}$ and R_{iso_neg} , R_{iso_pos}) satisfy the specified tolerance as soon as the status signals $R_{iso_status} = 0xFE$.

When the fast start measurement is deactivated (Power-On profile "Standard", "High Capacity", "Disturbed", "Service"), the specified tolerance is met only after 12 individual measured values have been obtained in the status $R_{iso_status} = 0xFE$.

An insulation resistance $R_{iso_corrected}$ is made available at the interface, and from which the currently valid "tolerance value" (set tolerance percentage times measured value) is subtracted. This ensures that this measured value never exceeds the actually present insulation resistance. The following example serves to illustrate this device function:

$R_f = 1 \text{ M}\Omega$, $R_{iso_original}$ (measured) = e. g. $1.05 \text{ M}\Omega \rightarrow$ tolerance $\pm 12 \%$

$R_{iso_corrected} = 1.05 \text{ M}\Omega - 1.05 \text{ M}\Omega * 0.12 = 924 \text{ k}\Omega$

Wiring diagram

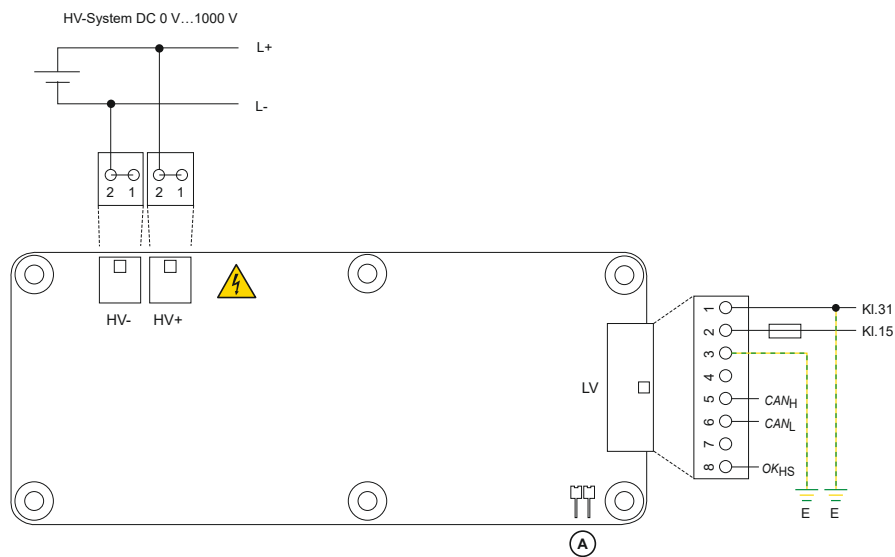

Connector*	Pin no.	Description
HV+	1	Mains voltage (L+)
	2	
HV-	1	Mains voltage (L-)
	2	
LV	1	Supply voltage - (terminal 31)
	2	Supply voltage + (terminal 15)
	3	Earth connection (E) ¹
	4	n.c.
	5	CAN-High
	6	CAN-Low
	7	n.c.
	8	Status output (high side) (OK _{HS}) ²
A	Jumper CAN terminating resistor 120 Ω ³	

- ¹ Pins 1 and 3 must be on the same potential for fault-free operation.
- ² The electrical design of the status output is an open-collector topology, which requires a pull-down resistor against terminal 31 for a defined output signal. Here a 2k2 resistor with a power rating of at least 1 W is recommended.
- ³ The ISOMETER® furnished with an onboard CAN-bus termination with 120 Ω, which can be activated by plugging a jumper (for a recommendation see chapter "Technical data") to plug connector A.
- * For details on the connectors required to connect to the HV system as well as to the supply voltage refer to "Ordering information".

For a functioning connection detection of LV pin 3 to chassis ground, the connection of LV pin 1 must also be connected to chassis ground.

Wiring example

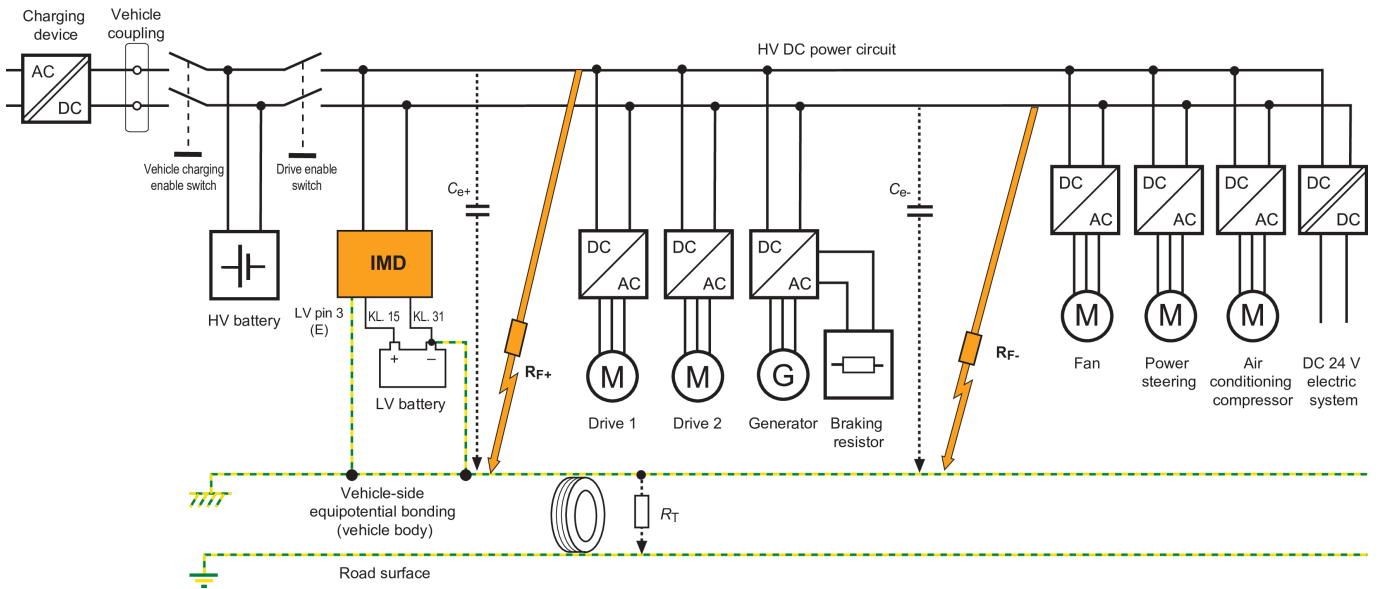

Dimension diagram

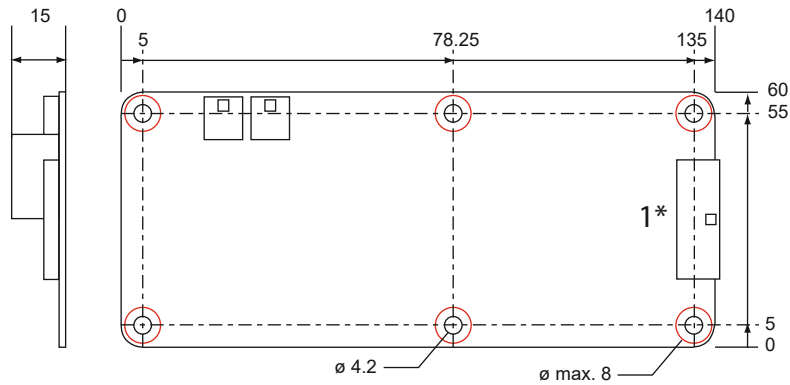

Dimensions in mm (L x W x H) 140 x 60 x 15 mm

1* LV: protrudes 1 mm from the printed circuit board edge

i Red markings: fastening positions

Technical data

Insulation coordination acc. to IEC 60664-1

Protective separation (reinforced insulation)	between (L+/L-) – (terminal 31, terminal 15, E, CAN _H , CAN _L , OK _{HS})
Rated impulse voltage	6000 V
Overvoltage category	II
Voltage test	DC 4200 V/ 1 min
Pollution degree	2

Supply / monitored IT system

Supply voltage U_s	DC 12...24 V
Tolerance Supply voltage U_s	-17...+50 %
Self consumption, no load at output	≤0.55 W
Max. operating current I_s	300 mA
HV voltage range (L+/L-) U_n	DC 0...1000 V
Tolerance U_n	+10 %
Recommended back-up-fuse	M 630 mA

Response values

Response value R_{an}	30 k...2 MΩ
Response value hysteresis (DCP)	25 %
Undervoltage detection	0...1000 V Default setting: 0 V (inactive)
Undervoltage detection hysteresis	5 %

Measuring range

R_iso_corrected	0...35 MΩ
R_iso_original	0...50 MΩ
Measuring range	
Insulation: R_iso_neg*	0...50 MΩ
Insulation: R_iso_pos*	0...50 MΩ
Voltage: HV system voltage measurement	0...1000 V
Tolerance Voltage: HV system voltage measurement	±5 % ± 2 V
Voltage: HV_pos_to_Earth	0...1000 V
Tolerance Voltage: HV_pos_to_Earth	±5 % ± 2 V
Voltage: HV_neg_to_Earth	0...1000 V
Tolerance Voltage: HV_neg_to_Earth	±5 % ± 2 V
Capacity: (capacitance) Measured_Value	0...10 μF
Tolerance Capacity: (capacitance) Measured_Value	tbd
Unbalance: Measured_Value	0...100 %
Tolerance Unbalance: Measured_Value	tbd
Relative uncertainty of the estimated measured values of the fast start measurement:	
R_iso_status = 0xFC)	0...-100 %
Tolerance "R_iso_corrected" (R_iso_status = 0xFD)	Measuring range 0...50 kΩ
	Abs. fault 0...-50 kΩ
	Rel. fault 50 kΩ...1.2 MΩ 0...-120 % to 0...-48 % 1.2...5 MΩ 0...-48 % to 0...-76 % 5...10 MΩ 0...-76 % > 10 MΩ not specified
Tolerance "R_iso_corrected" (R_iso_status = 0xFE)	Measuring range 0...50 kΩ
	Abs. fault 0...-50 kΩ
	Rel. fault 50 kΩ...1.2 MΩ 0...-60 % to 0...-24 % 1.2...5 MΩ 0...-24 % to 0...-38 % 5...10 MΩ 0...-38 % 10 MΩ not specified

* Available from an HV voltage > 100 V

Time response

Enabling time t_{start} (OK _{HS} ; fast start measurement)	≤ 5 s (C_e ≤ 2 μF)
Response time t_{an} (OK _{HS})	≤ 30 s
as per LV 123 (100...500 Ω/V, 2 μF (profiles: Standard/Standard with fast startup))	
Switch-off time t_{ab} (OK _{HS} ; DCP)/ insulation fault (100...500 Ω/Volt)	Profil Standard ≤ 55 s Profil High Capacity ≤ 60 s
until R_iso ≥ 10 MΩ, C_e ≤ 1 μF	Profil Distrubed ≤ 115 s Profil Service ≤ 36 s
Offline self test	≤ 1 s
Offline self test with output test (OK _{HS})	≤ 5 s

Measuring circuit

System leakage capacitance C_e max.	Standard profile	$\leq 5 \mu\text{F}$
	High Capacity (capacitance) profile	$\leq 10 \mu\text{F}$
	Disturbed profile	$\leq 10 \mu\text{F}$
Measuring voltage U_M		$\pm 35 \text{ V} \pm 2 \text{ V}$
Measuring current I_M at $R_F = 0 \text{ k}\Omega$		$\leq \pm 30 \mu\text{A}$
DC internal resistance R_i		$1.2 \text{ M}\Omega \pm 2\%$

Status output OK_{HS}

OK _{HS} (High-Side Treiber) high U_s	$\geq U_s - 2 \text{ V}$
OK _{HS} (High-Side Treiber) low U_s	$\leq 0,2 \text{ V}$
Permissible output current max.	80 mA

CAN interface

Data transmission rate	125, 250, 500, 666, 800, 1000 kBaud
Terminating resistor	120 Ω *

* via jumper: Recommended: Weitronic W+P Products Jumper series 165.
Manufacturer ordering no.: 165-101-10-00

EMC

Load-dump protection	$\leq 58 \text{ V}$
----------------------	---------------------

ESD protection

Contact discharge – directly at the terminals	$\leq 4 \text{ kV}$
Contact discharge – indirectly via the environment	$\leq 4 \text{ kV}$
Air discharge – handling of printed circuit board	$\leq 8 \text{ kV}$

HV connection

Cable length, max.	2 m
Cable cross section	AWG 20...24
Validated cable type	AlphaWire 5875

Environment

Operating temperature	-40...+105 °C
Temperature cycle (ISO 16750-4)	Ka
Air humidity (rH)	0...100 %
Altitude	$\leq 3000 \text{ m}$

Classification of climatic conditions acc. to IEC 60721

Transport (IEC 60721-3-2)	2K11
Long-time storage (IEC 60721-3-1)	1K21

Classification of mechanical conditions acc. to IEC 60721

Transport (IEC 60721-3-2)	2M4
Long-time storage (IEC 60721-3-1)	1M10

Other

Operating mode	Continuous operation
Flammability class as per	UL 94 V-0
Deflection	max. 1 % of the length or width of the PCB
Coating	Protective paint (ELPEGUARD® SL 1307 FLZ)
Weight	$37 \text{ g} \pm 3 \text{ g}$

Standards and approvals

The ISOMETER® iso175 has been developed in accordance with the following standards and approvals:

- IEC 61010-1
- IEC 60664-1
- IEC 60068-2-6
- IEC 60068-2-14
- IEC 60068-2-27
- IEC 60068-2-64
- ISO 6469-3
- ISO 16750-2
- ISO 16750-3
- ISO 16750-4
- (UN)ECE R10 Rev.6
- SAE J1939-82
- Insulation measurement functions based on: IEC 61557-8

Ordering information

Standard variants

Type	Connector type (connection)	Interfaces	Standard-configuration	Art. No.	Manual No.
iso175C-32-SS	TYCO ¹	HS-CAN SAE J1939	Baud rate: 500 kBaud Response value: 100 kΩ (error) 500 kΩ (warning)	B91068201	D00415
iso175C-42-SS	Samtec/Molex ²			B91068202	
iso175C-32-SB	TYCO ¹	HS-CAN Bender		B91068203	
iso175C-42-SB	Samtec/Molex ²			B91068204	

- ¹ HV+ / HV- connections
- Manufacturer: TE Connectivity / AMP
 - Series: Micro Mate-N-Lok™
 - Article number: 1445022-2

LV connection

- Manufacturer: TE Connectivity / AMP
- Series: Micro Mate-N-Lok™
- Article number: 1445022-8

- ² HV+ / HV- connections
- Manufacturer: Molex
 - Mini-Fit Jr.®
 - Article number: 39-01-2025

LV connection

- Samtec
- Mini Mate®
- IPD1-08-S-K

Cable recommendation for proper functioning of the offline self test: AlphaWire (Art. No. 5875)

i CAN configurations (e.g. baud rate and addressing) cannot be changed later.

Customized variants*

Type	Connector type (connection)	Interfaces	Customer-configuration	Art. No.	Manual No.
iso175 customized	TYCO (side) or Samtec/Molex (top)	HS-CAN (SAE J1939 or Bender)	According to customer specifications	B91068200	D00415

* For sales contact data and further information see "<https://www.bender.de/loesungen/emobility/>".

Accessories

Description	Suitable for type	Art. No.
IR155 / iso175 fastening kit	All	B91068500
IR155 / iso175 connection kit (TYCO)	iso175X-32-XX	B91068501
IR155 / iso175 connection kit (Samtec/Molex)	iso175X-42-XX	B91068502



Bender GmbH & Co. KG

Londorfer Straße 65
35305 Grünberg
Germany

Tel.: +49 6401 807-707
emobility@bender.de
www.bender.de



© Bender GmbH & Co. KG, Germany
Subject to change!
The specified standards take into account the edition valid until 08.2024 unless otherwise indicated.